

TECHNICAL DATA

Three Phase Electric Motors - Cast Iron Frame
 PE30 112M-8
 1.5 kW / 2 Cv
 690 RPM

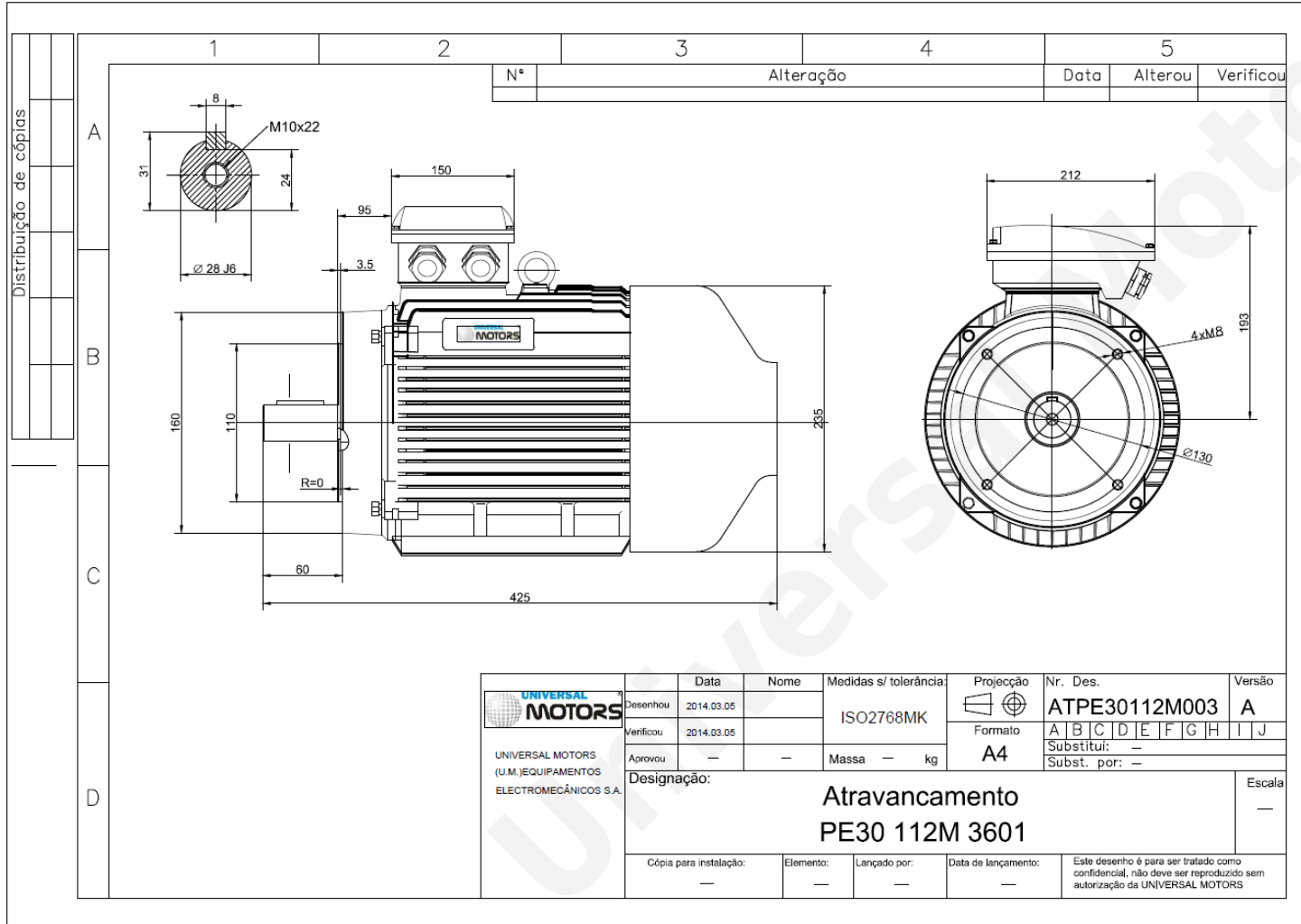

Motor type:	PE30 112M-8
Output:	1.5 kW / 2 Cv
Speed (min ⁻¹):	690 RPM
Frequency:	50 Hz
Voltage:	400 V
Current:	3.90 A
Power factor (Cos Ø):	0.70
Poles:	8
Insulation class:	F
Temperature rise Class:	B
Efficiency 50%:	74.6 %
Efficiency 75%:	79.9 %
Efficiency 100%:	79.7 %
Torque:	21 N.m
Tstarting/Tnominal:	1.8
Istarting/Inominal:	5.0
Tmaximum/Tnominal:	2.0
Noise:	61 Db(A)
Weight:	47.5 Kg
Bearing DE:	6306 2Z C3
Bearing NDE:	6306 2Z C3

Regime - S1

Altitude - 1000m

Environment Temperature - 40°C

CONTACTS:

UNIVERSAL MOTORS Tel: +351 252 299 080
 Rua de São Brás,745 Fax: +351 252 299 089
 4480-782 VILA DO CONDE Mail: geral@universalmotors.pt

* References applied only in the UK